

NX User Defined Features

Automates usage of common design elements and simplifies the product model

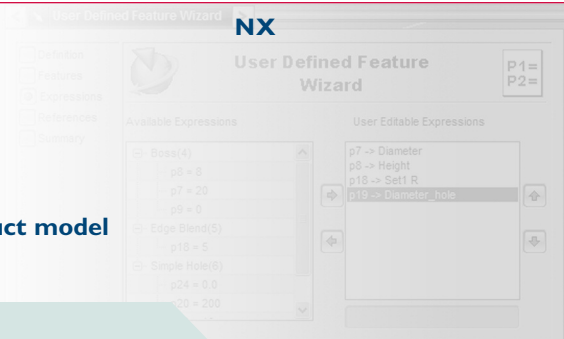

fact sheet

Siemens PLM Software

www.siemens.com/plm

Summary

With NX® software's User Defined Features, companies can customize NX to include a set of features common to their particular design practices. User Defined Features streamline the design process, promote re-use and ensure that product designs follow common methods and utilize standard design components.

Benefits

- Reduces repetitive design operations by using customized design elements
- Eliminates design variability and encourages adherence to company design standards
- Automates the use of commonly used design elements
- Simplifies the product model
- Supports re-use initiatives

Features

- Collect multiple design elements (features and operations) into a single feature
- Can predefine size and shape options to reflect company standards
- Includes a specially designed creation wizard with help instructions and re-use dialog
- Features are organized into libraries
- Features are integral design elements for knowledge-driven automation and manufacturing

NX User Defined Features, and the libraries to manage them, are tools within NX for establishing and maintaining standard parts, as well as standard feature sets. User Defined Features can be employed when repeated application of a single feature, even one with a simple shape, is required, or when the shape of the feature must be limited to meet company standards.

For example, standard holes, pockets, pads, embosses, flanges and cutouts can be organized into User Defined Features libraries.

User Defined Features can also be used to create sets of features that are applied together – for example, gear teeth, stiffeners, machined pockets, grooves, hole patterns, shafts with varying diameters, flats or other features.

By associating User Defined Features with other model dependencies, or by applying knowledge driven rules, the size, shape or orientation and even the composition of User Defined Features can be controlled as a set. For example, the size and shape of the drive hole on a rotating object might change based on torque requirements.

Not only do User Defined Features assure good design practices, but they can also be used to ensure quality and manufacturing objectives. NX User Defined Features allow the designer to extend the range and power of NX to create custom features and automate the use of commonly used design elements. These custom features can be a combination of NX features (form and operation) and controlling expressions. During User Defined Features creation, the designer defines the shape and control characteristics (external references and parametric values) of User Defined Features and stores it in a hierarchical library.

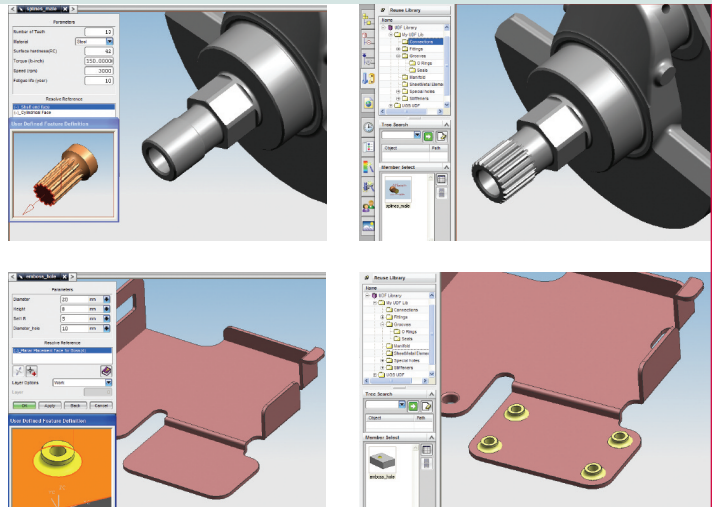

User Defined Features can then be accessed and inserted into new parts by anyone who has access to the library. When inserted into a new model, User Defined Features behave as a single feature. The size, shape, orientation and tolerances for the User Defined Features are controlled with each instantiation, as allowed by the original definition.

For maximum design productivity and control of design variability, repetitive design operations should be combined into a library of standard features. Application of these features should be constrained to allow only specific parameters to be modified. This ensures consistent adherence to company best practices and industry design standards.

During User Defined Features creation, an option is available to allow individual instances of User Defined Features to be exploded into their constituent features. If explosion is allowed and selected by the user, individual features within User Defined Features can be edited or manipulated after insertion. If explosion is not allowed, each instance of the User Defined Feature set is treated as a single feature. This means that a single operation (delete, suppress, copy/paste) applies to all of the features contained within User Defined Features.

The use of wizards

A “wizard” is available to assist the designer in the initial definition of User Defined Features. The wizard allows the generation of graphical images to act as guidance when the feature is re-used, and the definition of rules to control the acceptable range of variables that control the feature when it is used. The wizard also enables the definition of custom prompts that help engineers understand the inputs required. Attaching help files at creation time also increases the value of User Defined Features, ensuring communication of design intent.

Restricting available options when re-using User Defined Features can enforce company standards. Sizes can be restricted within an acceptable range or to the selection of explicit choices.

When the feature is re-used, a separate dialog guides the user through the process required to re-use User Defined Features and to edit, if required, at a later date.

Managing feature libraries

Teamcenter® software (Siemens PLM Software’s digital enterprise management solution) can be used to manage libraries of features.

Teamcenter tracks the usage of the User Defined Features and ensures traceability for standard features. Teamcenter can also be used to control access and manage feature revisions if the design criteria change.

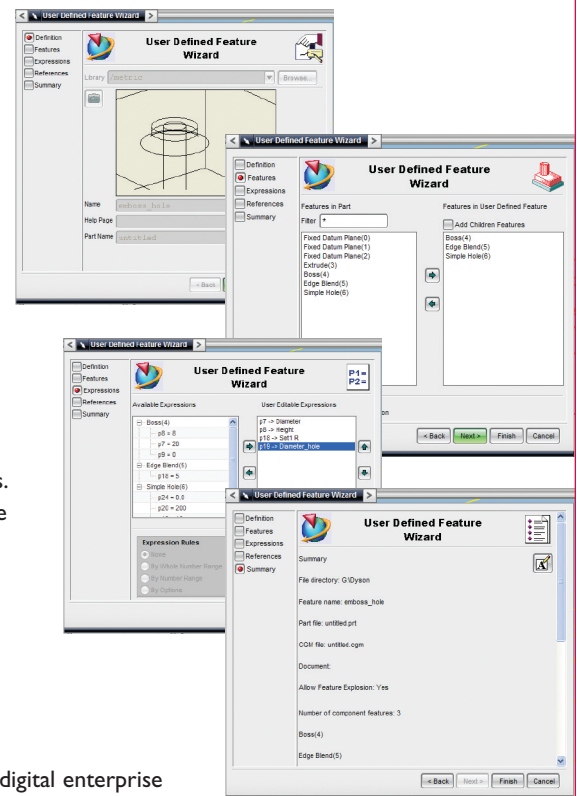

NX Knowledge Fusion extensions

When combined with NX Knowledge Fusion, User Defined Features can take advantage of a robust set of additional Knowledge Fusion capabilities. Knowledge Fusion is an easy-to-use, fully integrated knowledge capture tool that allows the designer to create rules that capture the design intent and rationale behind design decisions allowing rules to be attached to the user defined feature. These rules can be used to alter the geometry, location and even the selection of the appropriate User Defined Features based on model conditions.

Through the use of Knowledge Fusion capabilities, User Defined Features capabilities are extended to include spreadsheet references, database access, external algorithms, inter-process applications, optimization and more. Changes to these external references can be used to update User Defined Features.

Geometric tolerances

NX Geometric Tolerancing allows the user to capture tolerance information in the design model and associate it with geometry. This enforces the creation of standard-compliant tolerances. When the user inserts User Defined Features that include tolerance features, those features are automatically recognized and renamed if the name already exists in the model.

CAM extensions

By associating standard manufacturing processes with NX User Defined Features, manufacturers can extend the re-use of company knowledge into areas outside of design. NX is delivered with a set of Knowledge Fusion enabled User Defined Features that contain CAM specific information. For example, there is a library of holmaking User Defined Features (such as cap-screw and fit holes). NX CAM process templates in NX Feature-Based Holmaking use these User Defined Features. By using User Defined Features, the design engineer is setting up the model for downstream automation.

► Contact

Siemens PLM Software

Americas 800 498 5351

Europe +44 (0) 1276 702000

Asia-Pacific 852 2230 3333

www.siemens.com/plm

