

# NX Assembly Path Planning

Automatic definition of collision free extraction paths for components

fact sheet

Siemens PLM Software

[www.siemens.com/plm](http://www.siemens.com/plm)

## ► Summary

NX® Assembly Path Planning software automates the definition of collision free extraction paths for components in the context of accessibility, maintainability and assembly/disassembly studies. The software also enables creation of motion envelopes for clearance purposes and definition of keep out zones.

## Benefits

Assembly Path Planning provides users many benefits that include:

Fast generation of very complex extraction paths

*Streamlined workflow* – as part of the assembly sequencing application, definition of extraction paths and motion envelopes enables users to define all necessary functions within a single, integrated environment. The steps defined by an extraction path may be part of a longer sequence which includes component motion and other disassembly steps. Generation of motion envelopes may span all or any subset of these sequencing steps.

*Support of multi-CAD environments* – even if supplier parts are generated in other CAD systems and brought into NX via the JT file format, path planning will enable users to define extraction paths and motion envelopes for those components.

## Extraction path

Accessibility, serviceability and ease of assembly or disassembly are critical to the successful design and layout of complex products. Product design often requires parts to be packed together in tight spaces. Regardless of industry, designers need to know early in the product lifecycle whether it will be possible for manufacturing to assemble their products in a cost effective way. It is also important to know that field personnel will be able to easily service products in order to minimize down time for their customers.

The extraction path functionality is embedded within the assembly sequencing environment in NX. Its biggest strength is the ability to quickly find collision free extraction paths for components or subassemblies, where the extraction path is complex or not obvious to a designer.

## Key features

The extraction path functionality has many key features that include:

- *Automatic resolution for a collision free starting position* – if the component to be removed is already interfering with other components, NX can automatically move it to a valid, collision-free starting position
- *Limits of movement for translations and rotations* – this allows the user to guide the system onto a preferred direction for the extraction path (e.g. extracting a radiator from the top instead of the bottom of the car). It may also limit the rotation of the selected components in cases where their orientation may not exceed a certain angle (e.g. liquid filled components to prevent spillage)

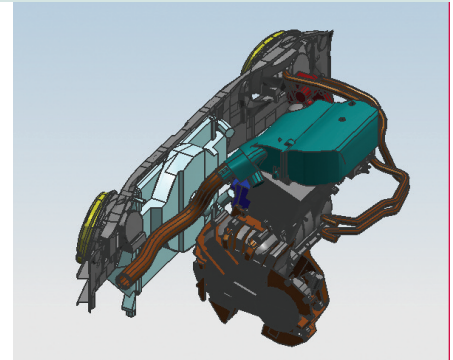

Starting point

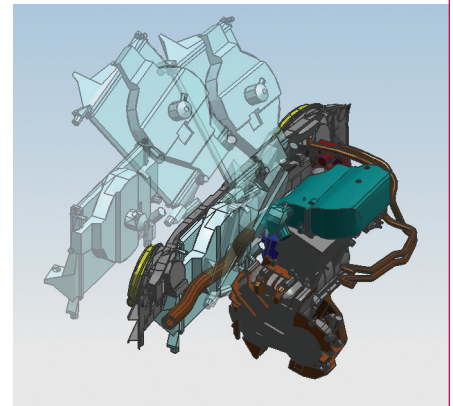

Resulting extraction path

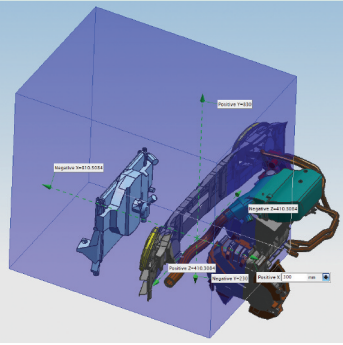

Limits of movement

- *Generation of smooth path* – once a collision-free path is found, the system will automatically provide a smooth result
- *Solid/lightweight input* – extraction path may be generated based on precise or lightweight (JT) bodies
- *Extraction path integrated into assembly/disassembly steps of other components within the assembly* – as part of the sequencing application the extraction path may be embedded in the middle of the assembly or disassembly process

### Motion envelope

When products are designed with accessibility in mind, it is important to be able to define keep out regions which must be left clear of components. Designs also need to account for component motion to ensure that necessary clearances are maintained as this motion is activated.

The motion envelope functionality is also embedded within the assembly sequencing environment in NX.

### Key features

The motion envelope functionality has many key features that include:

- *Solid/lightweight input* – motion envelopes may be generated based on one or multiple precise or lightweight (JT) bodies
- *Step selection* – users may generate a motion envelope for a subset or all of the steps in an assembly sequence
- *Quality setting control* – depending on the desired accuracy for the output envelope, users may select low, medium, high or custom quality settings. The purpose of the control is to achieve the right balance between precision and performance
- *Background processing* – users may choose for the envelope to be computed as a batch process to enable them to continue working in NX while the shape is generated

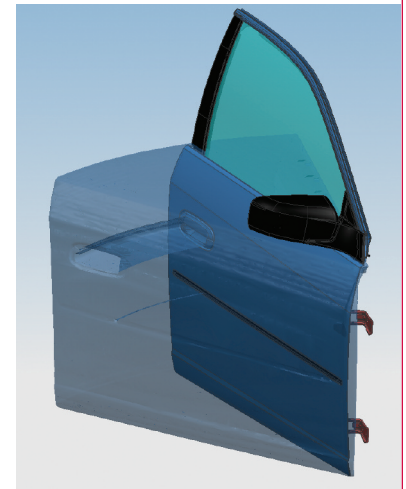

Motion envelope



Resulting envelope shape

► **Contact**  
**Siemens PLM Software**  
**Americas 800 498 5351**  
**Europe +44 (0) 1276 702000**  
**Asia-Pacific 852 2230 3333**  
[www.siemens.com/plm](http://www.siemens.com/plm)

**SIEMENS**