

NX Thermal

Benefits

- Investigate multiple "what-if" scenarios involving complex assemblies
- Build assemblies by modeling heat flow between unconnected parts and components
- Simulate fully coupled thermo-fluid interactions by using NX Thermal with NX Flow and NX Advanced Flow
- Easily map results to a Nastran FE model for thermo-elastic analysis
- Leverage all the capabilities of the NX integrated environment to make quick design changes and provide rapid feedback on thermal performance

Features

- Thermal couplings for joining disjoint solid or surface meshes within an NX assembly
- Coupled thermo-fluid simulations with the NX Flow and NX Advanced Flow modules
- Mapping of temperature to structural models for thermo-elastic simulations
- Effective definition of loads and boundary conditions with reference to groups
- NX integrated thermal and heat transfer toolset

Summary

NX™ Thermal software provides heat transfer solutions as a module of the NX Advanced Simulation environment. NX Thermal can be used to simulate conduction, convection and radiation phenomena for complex products and large assemblies. NX Thermal addresses thermal analysis requirements in a wide range of industries including automotive and transportation, consumer products and appliances, energy, medical, high tech electronics and defense. NX Thermal can also be used with NX Flow, an NX-integrated CFD solution, for coupled thermo-fluid simulation.

FE-based finite volume thermal solver technology efficiently simulates heat transfer phenomenon

NX Thermal uses high order finite volume-based technology on a FE mesh to accurately and efficiently simulate heat transfer phenomenon. It combines the versatility of FE-based analysis with the accuracy of a finite volume

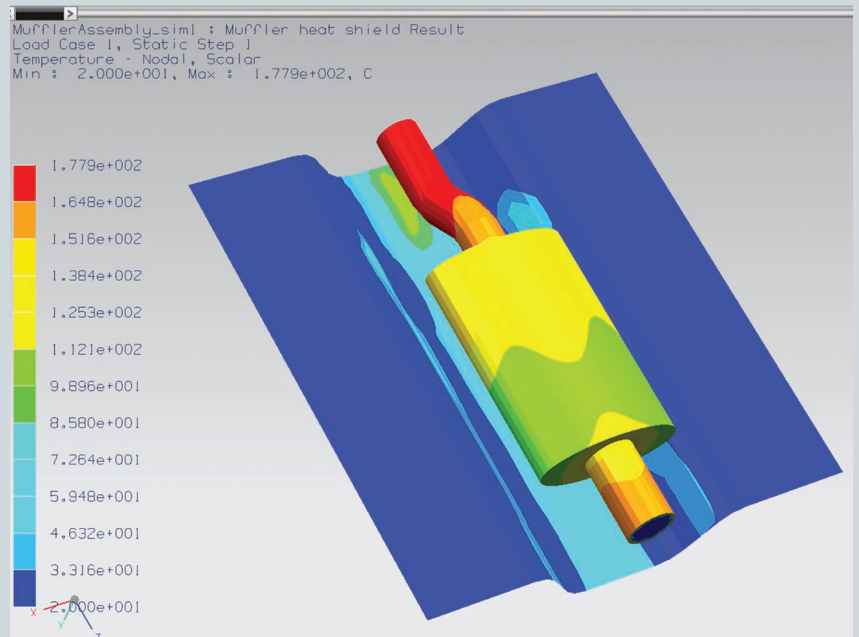

NX

www.siemens.com/nx

SIEMENS

NX Thermal

scheme. The NX Thermal solver technology allows simulation of NX parts and assemblies within complex thermal environments. The solver and modeling features include:

Solver capabilities

- Steady-state (linear and nonlinear)
- Transient (linear and nonlinear)
- Material nonlinear thermal properties
- Axisymmetric modeling
- Cyclic thermal problems
- Iterative conjugate gradient solver technology
- Fully coupled conduction, radiation and convection heat transfer simulation
- 10 choices of consistent units to be used for runtime messages
- Mapping of temperatures to dissimilar structure FE model

Element types supported in NX Thermal

- 0D concentrated mass
- 1D beam
- 2D triangular and quad thin shell, null shell, uniform and nonuniform multi-layer, linear or parabolic
- 3D linear or parabolic tetrahedral, brick, wedge and pyramid
- Linear and parabolic axisymmetric wedge and brick

Thermal couplings technology for modeling thermal contacts within NX assemblies

- Thermally connect disjoint and dissimilar mesh faces and edges
- Surface-to-surface, edge-to-edge or edge-to-surface contact modeling between parts: constant, time- or temperature-dependent coefficient of heat transfer, resistance or conductance
- Radiative exchange between disjoint part faces and faces within a single part

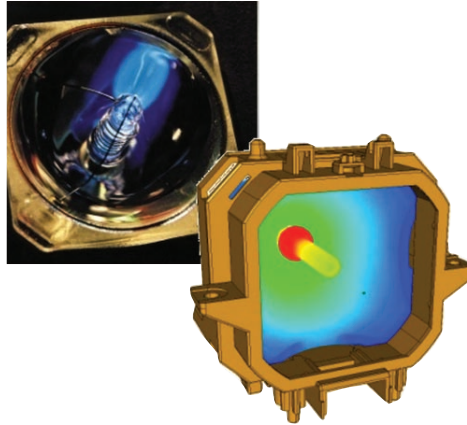

- Interface modeling between connected parts: constant, time- or temperature-dependent coefficient of heat transfer, thermal resistance or conductance, edge contact or conductive gap
- Spatially varying heat transfer coefficient can be defined for thermal couplings

Applied heat loads

- Constant, time and spatially varying heat loads
- Constant, time and spatially varying heat flux
- Constant, time and spatially varying heat generation
- Ability to control all applied loads with temperature-controlled thermostat or PID controllers

Temperature boundary conditions

- Constant, time and spatially varying temperature
- Thermostat temperature controls

Conduction heat transfer

- Ability to handle large conduction heat transfer models
- Temperature-dependent conductivity
- Temperature-dependent specific heat
- Orthotropic conductivity
- Phase change at temperature or over temperature range

Convection heat transfer

- Constant, time and spatially varying heat transfer coefficient and environment temperature
 - Parameter and nonlinear temperature gradient functions
- Free convection
- Correlation-based free convection to ambient for inclined plates, cylinders and spheres and parallel plate channels
- Forced convection
- Correlation-based convection for plates, spheres and cylinders in forced fluid flow

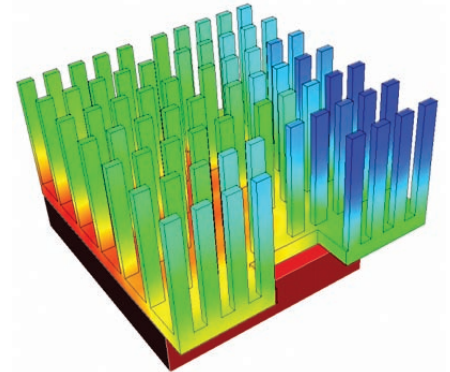

Radiation heat transfer

- Constant and temperature-dependent emissivity
- Multiple radiation enclosures
- Diffuse view factor calculations with shadowing
- Net view factor calculations
- Adaptive scheme for view factor sum optimization
- Hemicycle-based view (form) factors calculation using graphics card hardware
- Radiation patch generation to condense large element-based radiation models
- Radiation matrix controls and parameters

Initial conditions

- Starting temperatures for both steady-state and transient
- Starting temperatures from previous solution results, from file

Solver and solution attributes

- Restart conditions, cyclic convergence criteria
- Direct access to solver parameters
- Solver convergence criteria and relaxation factors
- Solver monitor with solution convergence and attributes
- Intermediate results display and recovery directly from solver progress monitor

Other features

- Result reports
 - Summary of results to html pages and comma separated value (.csv) files compatible with Excel
 - Heat flow calculation between groups
 - Heat maps
- Complete or partial deactivation of selected elements (for radiation form factors calculations)
- Temperature mapping for Nastran FE models with dissimilar mesh

Simulation results

- Temperatures
- Temperature gradients
- Total loads and fluxes
- Conductive fluxes
- Convective fluxes
- Convection coefficients
- Residuals
- Heat maps
- View factors sums

Simulation features

Thermal couplings for joining disjoint solid or surface meshes within NX assembly context

Thermal couplings provide a powerful and efficient capability for building assemblies by modeling heat flow between unconnected parts and components. Multiple what-if scenarios and positioning of parts within an assembly can be investigated by defining the thermal coupling parameters between unconnected parts only once. Heat transfer paths are automatically created between elements on opposing parts at runtime. These conductances are established based on surface proximity, and account for overlap and mismatch

between disjoint and dissimilar meshes exchanging heat, allowing parts to be moved freely within the assembly prior to running the analysis. Thermal coupling types include conductive, radiative and interface couplings. Thermal couplings can also be defined as varying with temperature or time and space location.

Coupled thermo-fluid and thermo-elastic simulations

The heat transfer modeling capabilities can be explicitly combined with the NX Flow and NX Advanced Flow computational fluid dynamics (CFD) solution (also available within the NX Advanced Simulation environment).

These combinations allow a user to simulate strong and fully-coupled thermo-fluid interactions problems, including integration of radiative heat transfer. When NX Flow and NX Thermal are purchased together, the thermo-fluid simulation capability is automatically activated within NX at no additional cost, offering both conduction and radiation modeling to be fully coupled with 3D fluid flow. Furthermore, NX Thermal temperature results can be mapped to a separate Nastran FE model for thermo-elastic analysis.

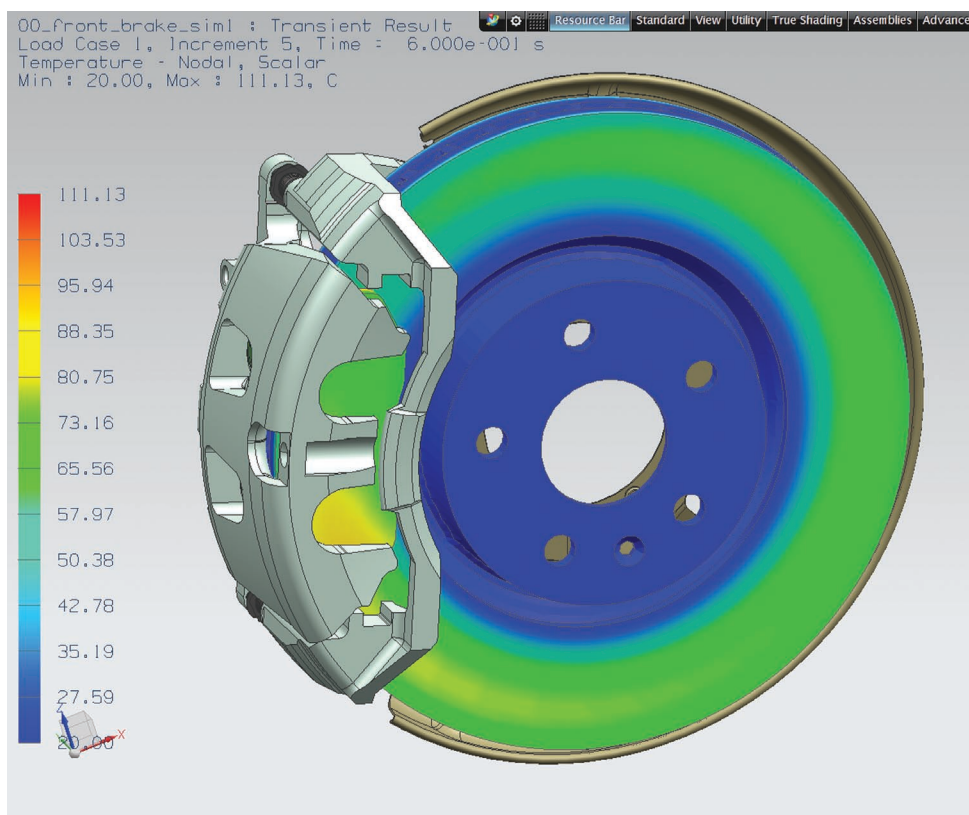
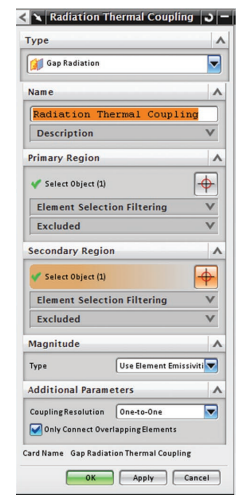

Native to NX, integrated thermal and heat transfer solution

NX Thermal is integrated within the native NX portfolio and takes full advantage of the NX Advanced Simulation environment including synchronous technology, allowing quick geometry modifications without regard to how it was built, as well as the distributed meshing workflows leveraging the Assembly FEM capabilities. The NX integrated application allows both skilled engineers and thermal specialists to avoid any additional transfer of input files or geometry conversions and manipulations breaking the associative link between the NX geometry and FE tasks. The thermal model is synchronized with the NX design and assembly intent through NX data associativity. Complete associativity with the design geometry means that the thermal mesh is automatically updated when the design or assembly is modified.

NX provides NX Thermal users with a broad set of tools for creating thermal models and analysis-ready geometry. A user can automatically (or manually) create an idealized part where easy abstraction of unnecessary geometrical

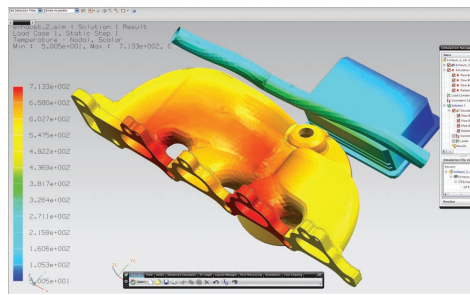

features can be achieved. Every geometrical abstraction is associative to the NX part and assembly context. Automated free meshing tools enable quick parts modeling using precise sketches, surfaces and solid geometry. The user can refine the mesh in critical areas and selectively control mesh density, minimizing or optimizing model size for rapid and accurate solution.

By virtue of being integrated within the NX environment, NX Thermal provides the ability to model, catalog and share parts and material libraries among the NX design team, thereby minimizing tedious rework and potentially costly modeling errors.

Product availability

NX Thermal is an add-on module in the suite of Advanced Simulation applications available within the NX architecture. It requires a core seat of either NX Advanced FEM or NX Advanced Simulation as a prerequisite. When used in combination with NX Flow, NX Thermal provides a coupled multi-physics solution for complex fluid flow/thermal applications.

NX Thermal is available on most major hardware platforms and operating systems including Windows and Linux.

Contact
Siemens PLM Software
Americas 800 498 5351
Europe 44 (0) 1276 702000
Asia-Pacific 852 2230 3333

www.siemens.com/nx

© 2010 Siemens Product Lifecycle Management Software Inc. All rights reserved. Siemens and the Siemens logo are registered trademarks of Siemens AG. D-Cubed, Femap, Geolus, GO PLM, I-deas, Insight, Jack, JT, NX, Parasolid, Solid Edge, Teamcenter, Tecnomatix and Velocity Series are trademarks or registered trademarks of Siemens Product Lifecycle Management Software Inc. or its subsidiaries in the United States and in other countries. All other logos, trademarks, registered trademarks or service marks used herein are the property of their respective holders.
X10 6709 10/10 B