

NX Advanced 5 Axis Machining

Benefits

- Automated hole making capability speeds common processes
- Boundary-based cutting provides flexibility to cut on minimal geometry
- Solids-based cutting cuts complex shapes intelligently
- HSM support maximizes machine tool investments
- Smooth cutting capabilities keep feed rates high and provide fine finishes
- Streamline patterns fit cutting strokes to the surfaces so the passes flow along the part naturally
- Intelligent rest milling options allow associative multi-stage roughing techniques
- Master model capability ensures that NC development stays associative to the source model
- Model Edit capabilities make it easy to adjust model for optimal NC programming
- Integrated postprocessor and Post Builder provide production-ready output
- All supporting functions are provided

Summary

The NX™ Advanced 5 Axis Machining product provides a complete CAD/CAM package focused on milling any geometry with up to 5 axes of simultaneous motion. High speed machining, 5 axis machining capabilities are provided along with a full CAD seat.

Flexible Machining Coordinate System (MCS)

With NX CAM, you can make holes and planar cuts anywhere on the part, using any valid tool axis. These 2.5 axis cuts can be performed by 3+2 positional machines in any orientation.

Hole making

Extensive hole making functions are provided for spot drill, drill, ream bore and tap. You can use deep drill, peck drill and special boring cycles. User-defined cycles provide any needed hole making capability. Efficient traverses minimize lifts while accounting for all part and fixture geometry. Special multi-axis filtering automatically switches MCS for non-parallel hole selections.

Feature-based automation

You can take advantage of automatic feature processing that comes standard with NX. Feature recognition, process application and tool selection functions automate hole making for common classes of holes. Custom process development is separately available.

Face milling

Solids-based face milling automatically respects part and fixture boundaries while efficiently clearing faces.

Boundary cutting

You can trace boundaries the traditional way with either edges or wireframe elements. You can individually specify offsets, compensation, etc. for boundary elements. These boundaries serve as the basis for either single-trace cuts or area clearing patterns.

Generic motion control

You can build step-by-step tool motion with interactive drag handles and chain together cut traces with the most efficient transitions.

NX

NX Advanced 5 Axis Machining

Probing cycles

NX CAM performs on-machine probing with the included Renishaw probing cycles for single-tip probes. You can measure faces, holes and bosses.

Generalized roughing

NX CAM roughs any generalized 3D shape with intelligent multi-level volume removal patterns and automatically cuts levels corresponding to horizontal faces. Area clearing patterns include zig, zig-zag, part offsets, blank offsets and trochoidal.

High speed machining (HSM)

NX CAM provides specialized HSM patterns for either boundary or solids based roughing. You can keep your tool path smooth with corner treatments, stepovers, engages and retracts for the highest possible feed rates. You can optimize spindle speeds, feed rates and engagement depths for maximum safe material removal with the included cutting parameter library. Trochoidal loops protect tools from excessive engagement. When complete corners are required, feed rates automatically reduce to account for heavier local tool loads.

Z-level finishing

You can create z-level or waterline finishing passes on complex 3D geometry. Suitable for relatively steep areas, these cuts provide zig and zig-zag options with smooth engages, retracts and stepovers.

Rest machining

For re-roughing, NX CAM cuts only the areas untouched by previous roughing operations. You can use smaller tools only as needed for corner cleanout and use longer tools only as needed for deep reaches.

Independent projection vector

NX CAM enables you to achieve the smoothest tool path results in steep areas by specifying a projection vector different from the tool axis.

Smooth raster cutting

You can output the smoothest raster or zig-zag cuts with special stepover moves and optimized point distribution to maintain high feed rates and fine finishes.

Smooth offset cutting

NX provides smooth offset pattern cuts with special stepover moves and corner treatments to maintain high feed rates and fine finishes. You can cut inside out or outside in.

Steep/non-steep area recognition

You can limit raster cuts to non-steep areas for better cut depth control, as well as provide consistent semi-finish cuts with combination z-level and raster fill-in patterns.

Interpolated passes

NX provides tool paths that flow organically with your part faces. With these Streamline patterns, you can interpolate cutting passes between boundaries for the smoothest finishes. You can even cut true 3D spiral patterns with no stepover marks.

Automatic valley rest milling

NX discovers uncut valley material remaining from larger diameter tools, including bull-nose tools. You can cut the remaining tools along or across valleys.

NURBS output

You can output NURBS records for the smoothest machine motion and take advantage of high-level controller capabilities.

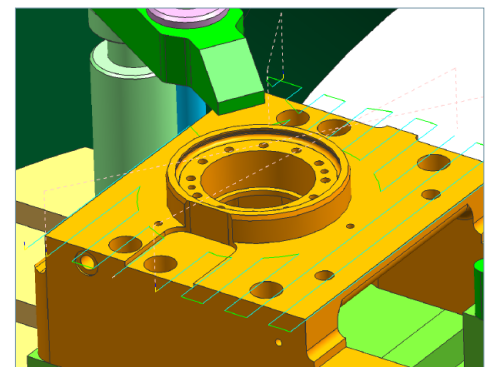
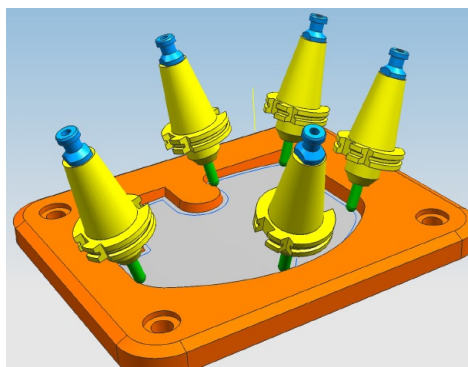
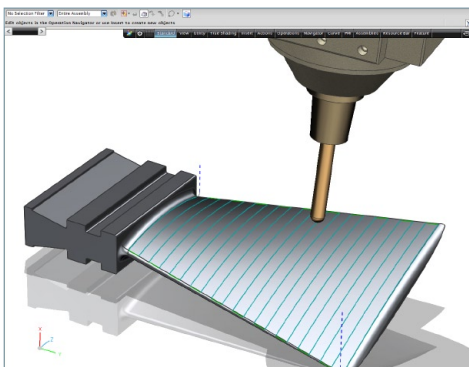

NX CAM benefits

- You can reduce setups with multi-axis milling
- Time saving templates control cutting motion and tool axis with a minimum of user input
- User control makes it possible to program virtually any 5 axis cut.
- Turbines and blisks are cut quickly and accurately

NX CAM features

- 5 axis surface area milling with lead/lag
- Contour profile provides swarf cutting
- Sequential mill provides cut-by-cut user control
- Turbomachinery milling for multi-blade geometry

Facet machining

With NX CAM, you can use scanned data or other faceted representations such as .stl and the JT™ format for NC programming.

5 axis tool tip cutting

You can trace area patterns across complex geometry while specifying tool axis lead and lag relative to the surface normal.

5 axis area patterns

All of the familiar 3 axis area clear patterns are provided with additional tool axis control. Raster cuts, offset patterns and interpolated cut strokes are all available.

5 axis swarf cutting

You can keep the side of the tool aligned with selected faces while controlling tilt.

Automatic 3 axis tilt

NX CAM invokes automatic tool tilt as a reaction to tool holder collisions in deep cavities. Tilting the tool over to provide clearance for the holder means cutting with shorter tools and keeping feed rates higher.

Turbomachinery milling

NX CAM optimizes programming for turbomachinery configurations, including multi-bladed turbines and blisks. Special operations for roughing and finishing blades and hubs maintain clearances even in the tightest blade configurations. Geometry inputs allow for imperfect and unstitched selections without slowing down the programmer with geometry repair.

5 axis user control

NX CAM includes high levels of user controlled 5 axis milling. You can control multi-axis tool motion with traditional drive, part and check surface specifications. These flexible options make it possible to program virtually any 5 axis cut.

Translators

You can read data from practically any CAD system with a set of translators for the Parasolid® software, IGES, DXF and STEP and JT formats. In addition you can write data in all of these formats, plus stl.

Operation navigator

From the CAM application's information center, you can create, view, modify, verify, inspect and organize your NC programs. You can manage tools, methods, geometry and output from an information-rich program display.

Tool path visualization

You can stay confident with tool path visualization and material removal verification tools. Integrated collision checking identifies any possible problems.

Tool path editing

You can make fast changes to tool path results with graphical editing tools and protect your edits by locking tool paths from future re-calculations.

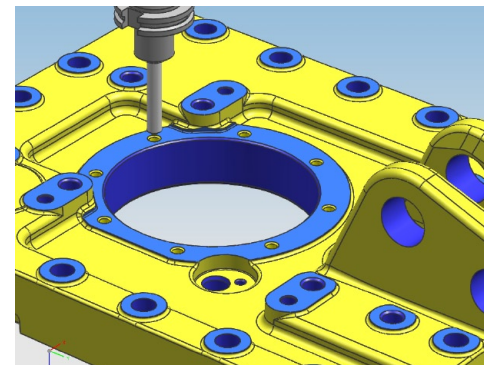
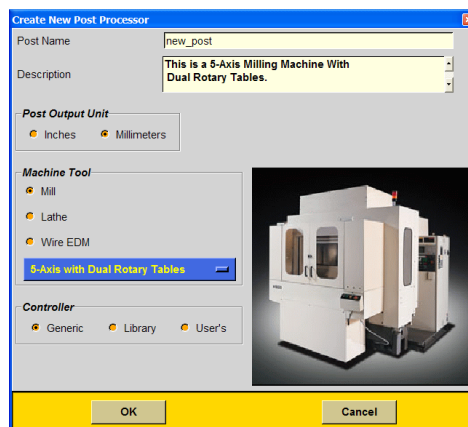
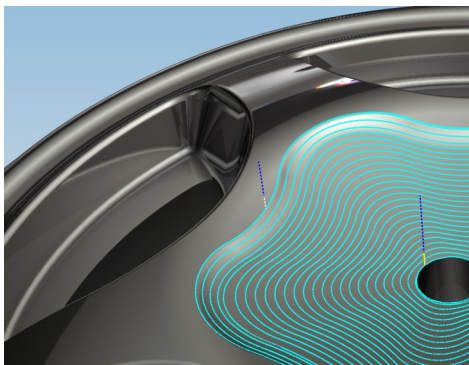

NC wizards

With the NC Wizard Builder, you can create semi-automated processes customized to your environment. The highly familiar wizard presentations enables you to streamline common tasks with the minimum user input.

Postprocessing

The Turning Foundation outputs production-ready g-code with integrated postprocessing. You can edit and fine tune existing postprocessors with our included interactive Post Builder application or even build a postprocessor from scratch using Post Builder templates. In addition, you can use included sample posts or download a post from our support library.

Shop documentation

You can produce html setup documents with the included shop doc capability.

Feed rate optimization

NX CAM helps you to easily maximize material removal rates and minimize tool wear. The ability to adjust feed rates to achieve a specified chip volume eliminates overloading as well as under-utilization of the cutting tool.

Assembly modeling

NX CAM includes important fixture components in the programming session and provides intelligent collision avoidance. Our master model concept keeps the assemblies and tool paths associative to your source model. NX assembly design supports “top-down” and “bottom-up” approaches and provides rapid navigation of the assembly hierarchy with direct access to the design model of any component or subassembly.

Model editing

You can perform important model cleanup tasks with key editing capabilities for:

- Surface extensions and patches
- 3D wireframe construction for boundaries
- Synchronous modeling
- 3D boundary flattening

Drafting

You can create engineering drawings that remain associative to your part models, including automatic view creation from solids, hidden line processing and automated parts lists. You can use templates to automatically create drawings for borders and view layouts.

Solid modeling

Using the CAD/CAM integration provided in NX Advanced 5 Axis Machining, you can develop 3D models with a full range of synchronous modeling and parametric modeling tools, including wireframe, primitives, swept and revolved bodies. Boolean operations and associative editing are supported. You can provide details such as blends, tapers and thin-wall features. NX modeling is powered by synchronous technology, Siemens PLM Software’s unique approach to 3D design that combines the power of parametric feature-based modeling with the freedom of history-free modeling.

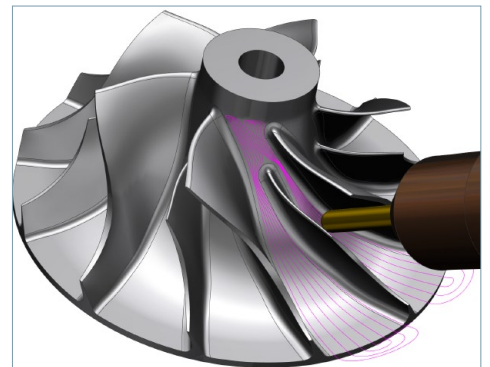
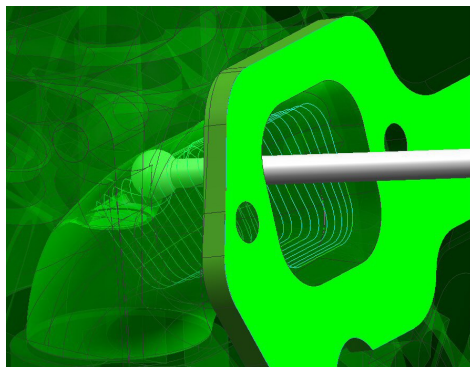
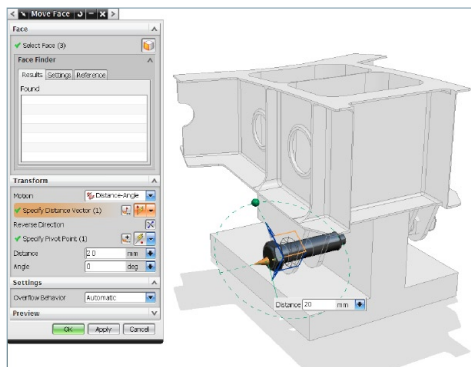

CAD/CAM benefits

- Full design capability with integrated CAD/CAM seat

CAD/CAM features

- 2D drafting
- Solid modeling
- Basic surface modeling
- Sheet metal modeling
- Advanced surface modeling
- Product manufacturing information

User-defined features

The integrated CAD/CAM capabilities let you capture and store families of features for easy retrieval and editing, starting with existing associative solid models. You can establish relationships between parameters, define feature variables, set default values and decide the general form the feature will take when started.

Basic surfacing

You can create complex surfaces and solid models using loft and sweep techniques, including multi-rail methods. You can also fine tune surfaces with surface extension and surface normal control.

Sheet metal

With the included sheet metal capabilities, you can create sheet metal component models using feature-based design tools for tabs, flanges and other typical features. You can use forming tables and bend sequence tables to account for bend deformation and generate accurate flat pattern data for manufacturing.

Associativity

You can absorb changes with ease with a fully integrated CAD/CAM system that keeps the NC program connected to the design model and updates to new geometry.

Available add-ons

You can configure the perfect CAM seat by adding the tool path creation options that your programs require. You can choose from:

- Turning
- Wire EDM
- Feature-Based Machining Author

Available Teamcenter integration

You can integrate your NX Mach CAM package with Teamcenter® software by including the NX CAM Teamcenter Client add-on. This Mach-level integration provides a managed environment for your NX data. Additional Teamcenter functionality is available separately.

Contact
Siemens PLM Software
Americas 800 498 5351
Europe 44 (0) 1276 702000
Asia-Pacific 852 2230 3333

www.siemens.com/nx

© 2010 Siemens Product Lifecycle Management Software Inc. All rights reserved. Siemens and the Siemens logo are registered trademarks of Siemens AG. D-Cubed, Femap, Geolus, GO PLM, I-deas, Insight, NX, Parasolid, Solid Edge, Teamcenter, Tecnomatix and Velocity Series are trademarks or registered trademarks of Siemens Product Lifecycle Management Software Inc. or its subsidiaries in the United States and in other countries. All other logos, trademarks, registered trademarks or service marks used herein are the property of their respective holders.
X9 23234 12/10 A