

NX CAM – Integrated Simulation and Verification

Real-time validation of the part machining process within the NC programming session

fact sheet

Siemens PLM Software

www.siemens.com/plm

► Summary

NX® CAM – Integrated Simulation and Verification (ISV) is a state-of-the-art application that enables the NC programmer to validate toolpaths and machine motion through digital simulation from within the programming session. The software is modular and covers toolpath and material removal simulation through complete machine tool motion simulation. Using advanced simulation technology, full 3D in-process representations of the part, coupled with gouge and collision checking methods, ISV eliminates the need to tie up expensive production equipment to verify manufacturability. ISV is fully embedded within NX CAM, allowing the simulation process to be simultaneous with programming and providing immediate, real-time feedback and validation.

Features

Verification of material removal and simulation of entire machine tool motion

Operates in NX CAM, within the NC programming session

Simultaneous collision detection and gouge checking

Accurate representation of machine tool kinematics and configuration

Modular software from metal removal verification to full machine tool simulation and the addition of new machines

Benefits

Checks proposed toolpath validity during CAM session for fast and easy problem identification and change opportunity

Faster and more efficient than conventional try-out methods

Automatic collision and gouge checking elements provide warning capability; avoids costly and dangerous errors

Allows the entire machine operation to be validated – not just the toolpath

Tooling, fixture and machine geometry needs to be created only once, reducing time and costs

The value of simulation and verification

Being able to simulate and verify a manufacturing process in the digital world can significantly improve the expectation that the task will execute as planned, with no errors, in the real environment. In the area of NC machining there are a number of areas that the programmer and manufacturing engineer would frequently wish to validate, before running a job on the machine tool. This ranges from

a detailed check of the proposed toolpath in terms of complete and correct material removal, without collisions or gouging, to a wider check on the overall machine motion to ensure that limits of travel are not exceeded and that there are no collisions with any part of the machine or fixtures.

Finding these problems early in the planning cycle minimizes schedule slippages, re-programming time and the risk of creating scrap parts.

NX CAM ISV products

The integrated simulation and verification (ISV) family of products within the NX CAM portfolio provides both toolpath and full machine tool simulation and verification.

The software is modular, with the entry level module, CAM Visualize, providing the toolpath and material removal verification. Machine Tool Simulation provides the ability to run simulations of the machining process within the context of a complete machine tool. Advanced Machine Tool Simulation adds the tools necessary to create new machine models with full kinematic definition for use in the simulation module.

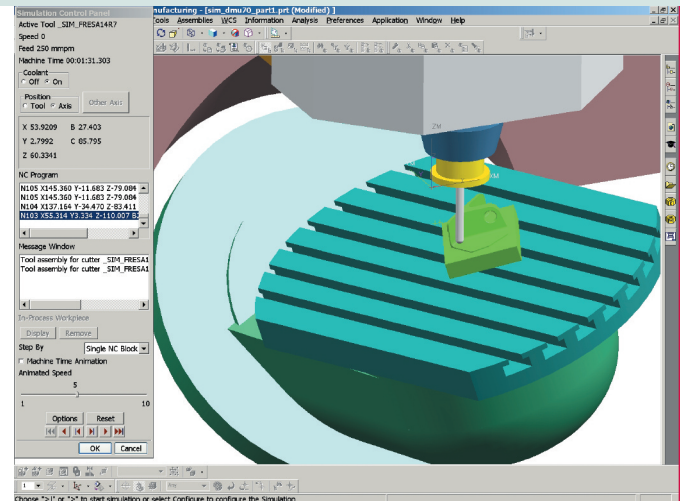

ISV products run within the NX CAM programming environment. This allows the programmer to run verification sequences as an integral part of the programming task. It avoids both the need to export data out of the programming system and having to create and maintain duplicate machine and tooling models for use in separate, external verification packages.

CAM Visualize

The ISV entry-level module, CAM Visualize, provides the CAM programmer with the ability to simulate machining operations with integrated verification of material removal and toolpath validation that is available during the programming session. In addition to the verification of the toolpath, CAM Visualize creates an accurate representation of the in-process workpiece to determine and display the current state of the machined part. The system allows the user to make measurements of stock and tooling and to visualize noncutting moves.

During the simulation, collisions and gouges can be displayed simultaneously. Collision detection considers the tool and the tool holder interacting with the workpiece, fixtures and other components of the machine tool and warns the user about possible collisions. No longer must the user rely on visual inspection of the animation in order to detect possible collisions.

The user is able to access and display tooling and fixtures from the integrated libraries available to NX CAM, including the Teamcenter[®]-based (Siemens' digital enterprise management solution) Resource Manager.

Machine Tool Simulation

The Machine Tool Simulation module provides users with the capability to simulate a complete machining environment. This enables the programmer to check the validity of the toolpath within the context of the complete machine tool. This simulation helps ensure that the key characteristics of the machine are not being violated and provides a more thorough analysis of the proposed machining process. The simulation includes all controller-dependent motions – for example, table rotation, cycles, macros and specific functionality triggered by the NC program (G and M codes). The software can accurately simulate machine- and controller-specific events, and the user can simulate an operation, a group of operations or the entire NC program.

The Machine Tool Simulation module includes a library of the most common machine tool/kinematics configurations available in the industry. For these machines, generic controllers (machine controller drivers) are supplied. Users are able to simulate the most common machining events, and the machine sizes can be edited.

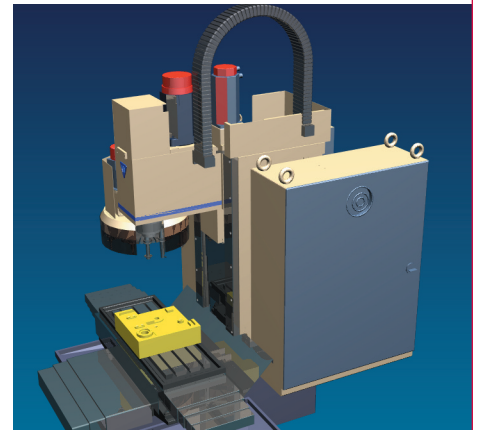

Advanced Machine Tool Simulation

The advanced module within the NX CAM integrated simulation and verification (ISV) product set provides all that Machine Tool Simulation offers plus the ability to define or modify machine configurations and/or driver characteristics. The module includes the machine tool builder and the machine tool driver

components of the machine tool simulation solution. The machine tool builder allows users to create their own machine tool definitions with geometry, linkages, kinematics and tooling. The machine tool driver is used to define machine controller drivers for the customizable virtual NC driver in the Advanced Machine Tool Simulation software. The module includes an interface to NX CAM Post Builder, so that machine controller drivers can be generated automatically from the specifications provided to the post builder. In order to provide the most reliable simulation possible, Siemens works with NC machine and controller partners to integrate software models of popular machine and controller types.

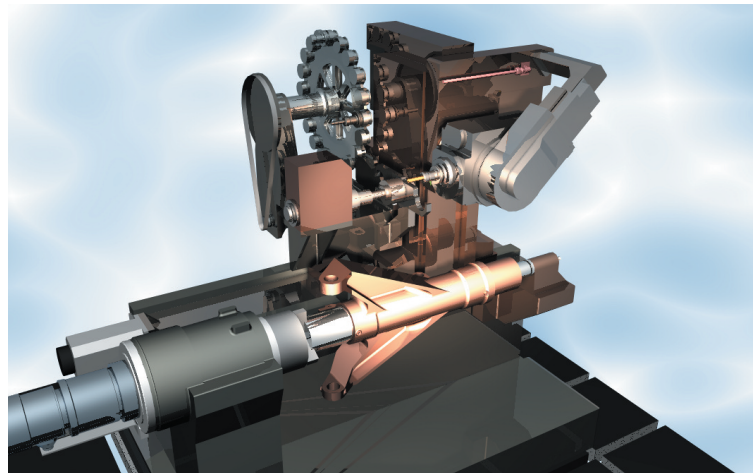
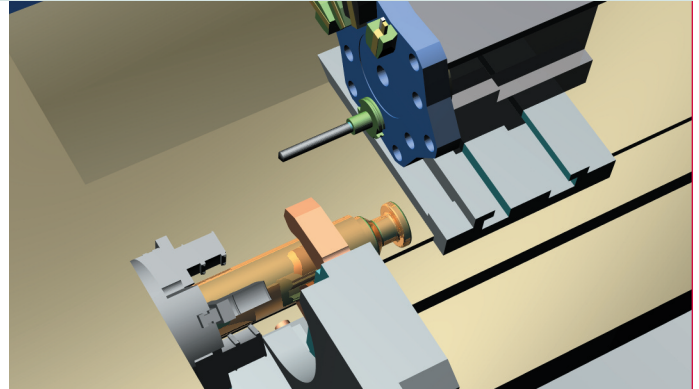

► Contact

Siemens PLM Software

Americas 800 498 5351

Europe +44 (0) 1276 702000

Asia-Pacific 852 2230 3333

www.siemens.com/plm

SIEMENS